

Specifications

Coverage: 500 sq ft to 5000 sq ft spaces,adjusts up to 7.5 ton / 3000CFM

Replacement Lamp: AS-IH-1013

Power Consumption: 0.67 A @ 24V

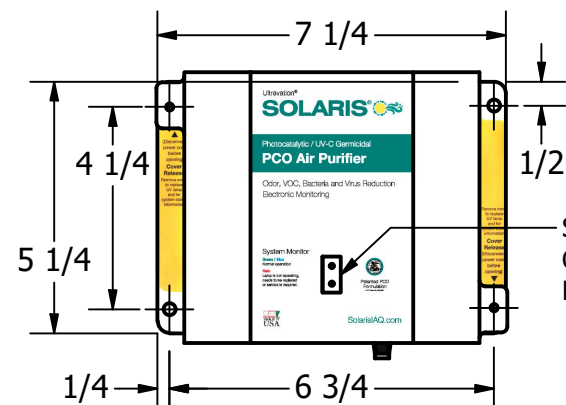

SYSTEM MONITOR
GREEN/BLUE LED: SYSTEM OPERATION GOOD
RED LED: LAMP/SERVICE REQUIRED

Input: Power In 24V,50/60Hz, 2.5 Amp

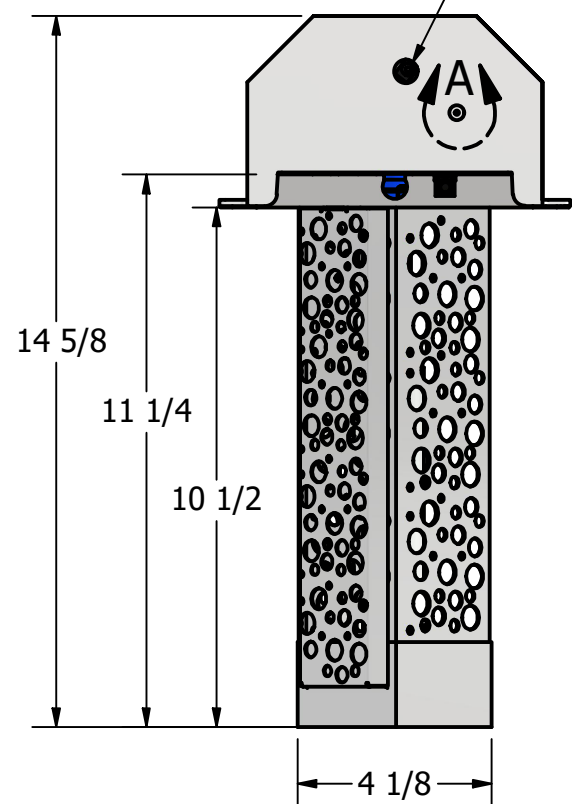

DETAIL A
[RESET BUTTON]
PRESS AND HOLD
10 SECONDS
AFTER EVERY
SERVICE

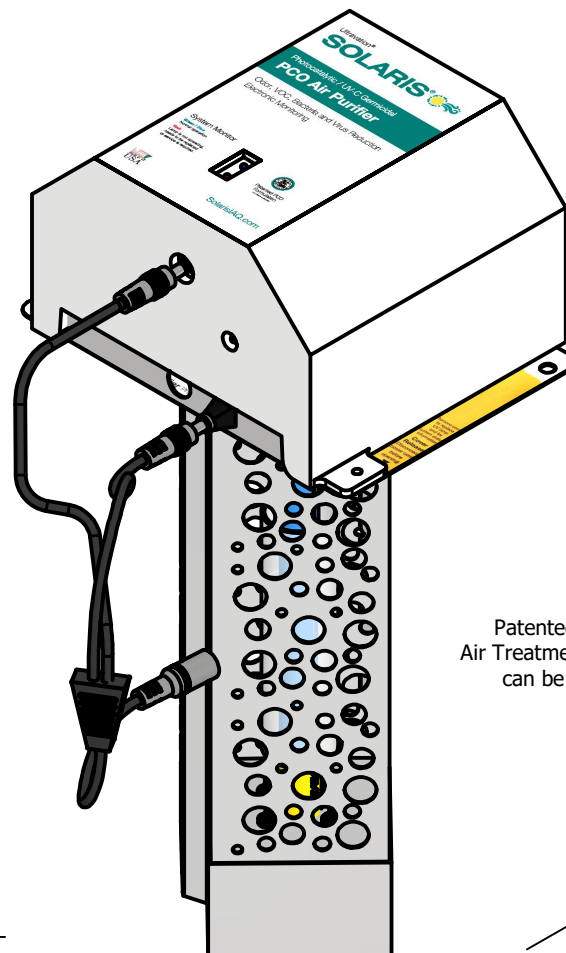
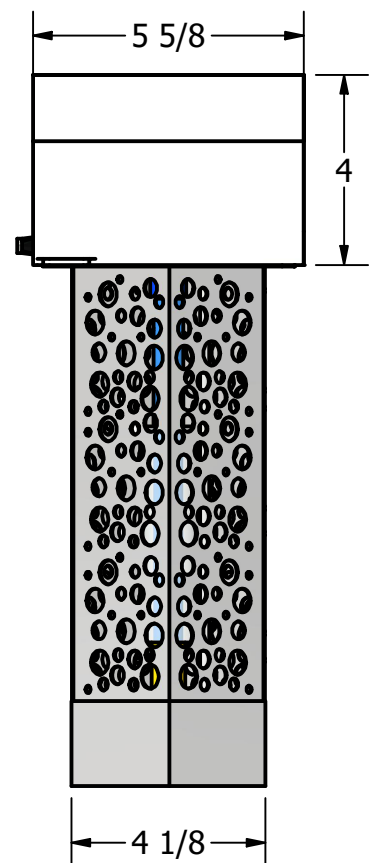

Ships with 40VAC multi-tap transformer
Input Voltage - Transformer 120V AC; 208V AC; 240V AC; 277V AC

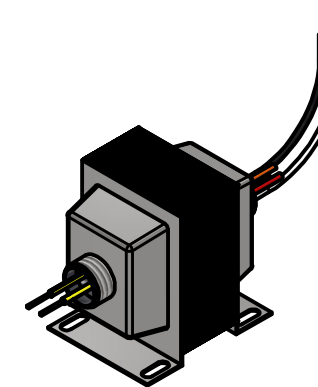

Patented adjustable dual spectrum
Air Treatment System- Photon clarifier
can be calibrated in sq. ft. or CFM

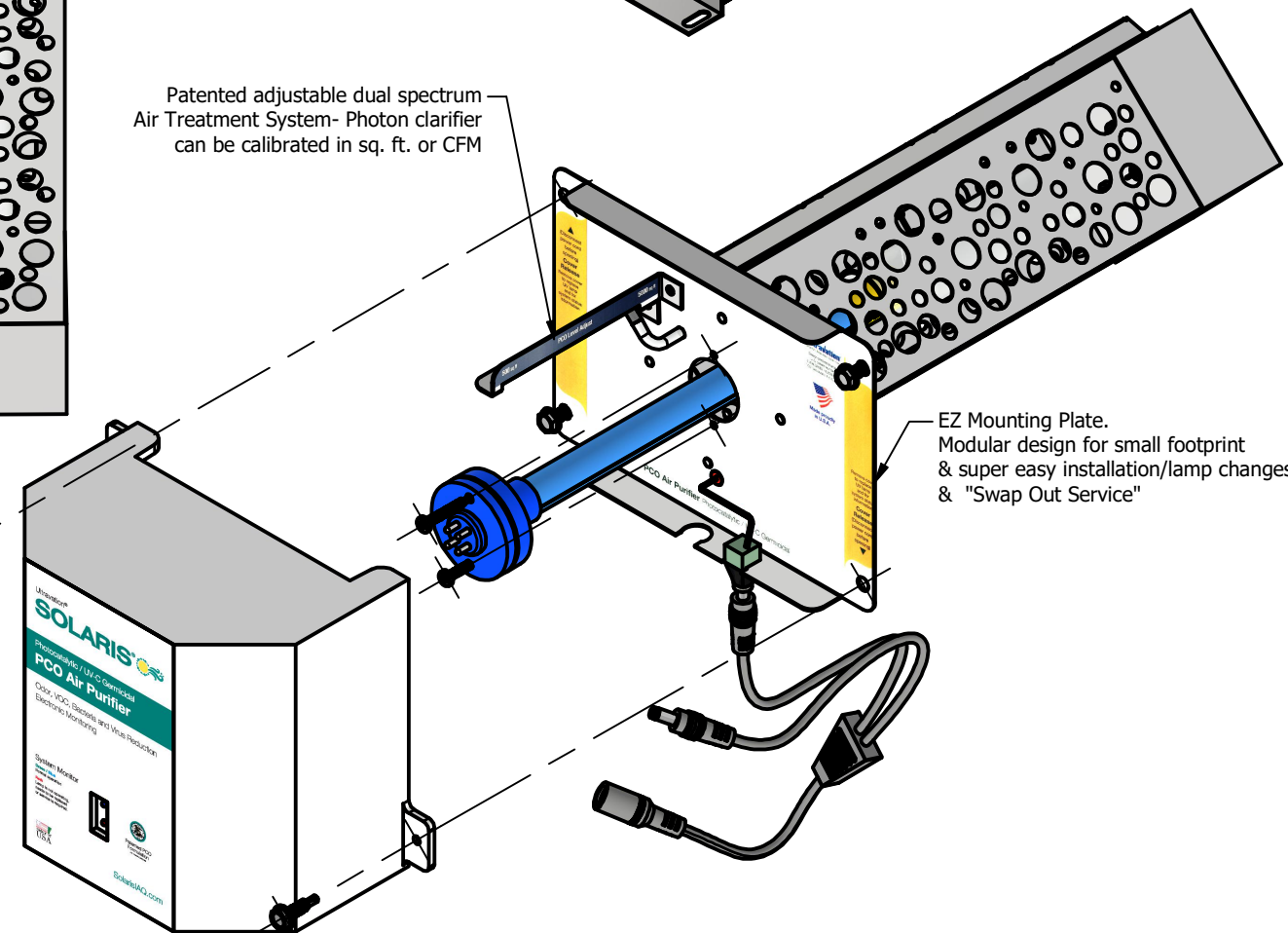

EZ Mounting Plate.
Modular design for small footprint
& super easy installation/lamp changes
& "Swap Out Service"

DRAWN	Anik D.	1/1/2022	ULTRAVATION INC.		
CHECKED	B. FOWLER	2/28/2023	67 TUBBS AVE, BRANDON VT-05733. 866-468-8247. www.ultravation.com		
QA			TITLE		
MFG			SLX1024		
APPROVED			Solaris LX Series PCO Air Purifier 24VAC with 4NP Ion Generator with duct board plate.		
			SIZE	DWG NO	REV
			A3	SLX SERIES	N/A
All Dimensions are in INCHES			SCALE	1/3	Tolerance ±0.031
			SHEET 1 OF 3		